

# Quick set up guide

**GENEE LINK**

Interactive module



*Leaders in learning technology*



---

# Quick set up guide for **Genee Link** interactive module

# Quick guide contents

---

Now that you have received your kit, you will want to get started straight away.

We want you to enjoy using this brilliant communication tool and have prepared this quick start guide to help you get up and running as soon as possible.

1. Package contents

---

2. Installing the hardware

---

3. Installing the software

---

4. Selecting the distance

---

5. Calibration

---

6. Using the Mouse mode

---

7. Using the Pen mode

---

8. Accessories

---

9. Icon functions

---

10. Support

---

# Package contents

---



The interactive unit



1.5m USB cable



Projector mount kit  
(including screws)



Pointer & light pen  
(including batteries)



Software CD



# Installing the software

---

Place the Software CD-ROM into the CD drive and copy the "LightPen II" folder from the CD-ROM onto your PC's hard disk drive.

Execute the "LightPen II.exe" software directly.

After executing the program, the LightPen icon should appear in the task bar. Left click on the task bar picture and then select **Preview Window**. A previewing window should now appear.

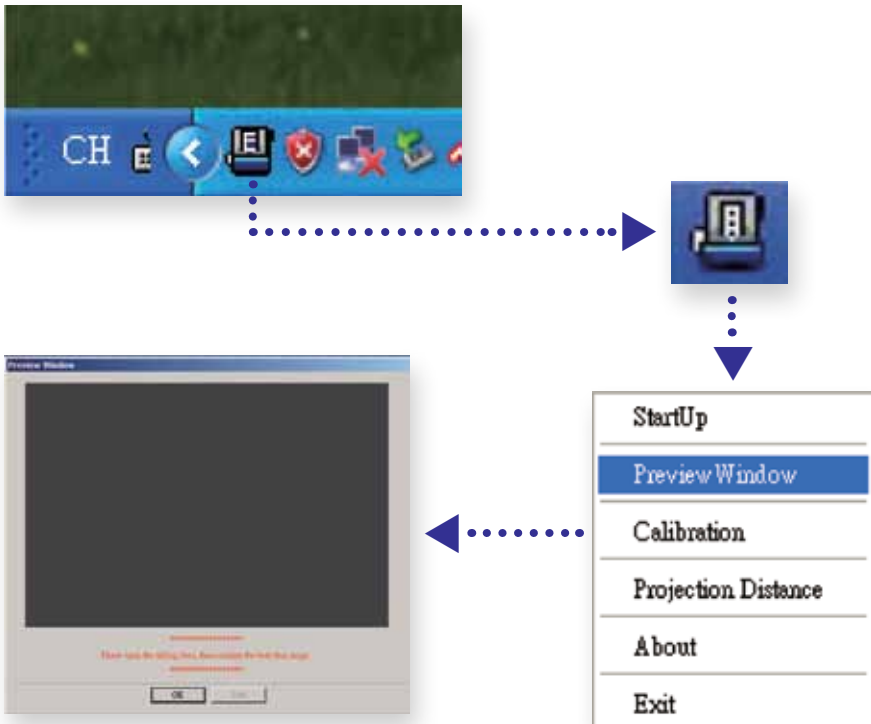

**Note** – Do not run the application software straight from the CD.

# Installing the software (continued)

Check if the projection image is within the viewing window.



**Left side** is outside viewing window



**Right side** is outside viewing window



**Top** is outside viewing window

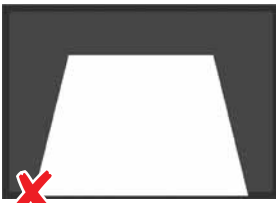

**Bottom** is outside viewing window



Projection image is **too small**



Projection image is **within** viewing window

After making sure the projection image is within the viewing window, close the lens cover. Now you can enjoy the interactive function by opening the "LightPen II" software.

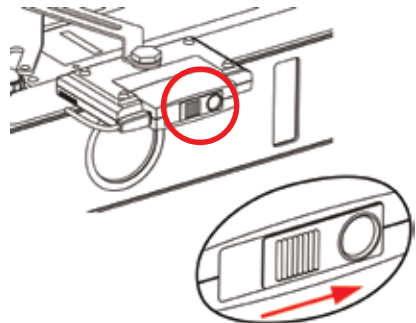

# Selecting the distance

---

Left click on the "LightPen II" figure in the task bar.



Select the "Projection Distance".

Choose the projection distance from the pop-up menu (>3m, >2m, <2m), and then click **OK**.



# Calibration

Left click on the "LightPen II" icon in the task bar.



Select the **Calibration**.

For the pointer, place the tip on the center of the green target and press the button. For the light pen, press the tip of the light pen on the center of the green target. The colour of the target should change from green to black.

This calibration starts from the upper left hand corner to the bottom right hand corner then to a "Z" shape in the middle of the screen.

The calibration is finished when all 13 targets turn black.

To ensure optimal precision, hold the light pen or pointer in the same direction during calibration.

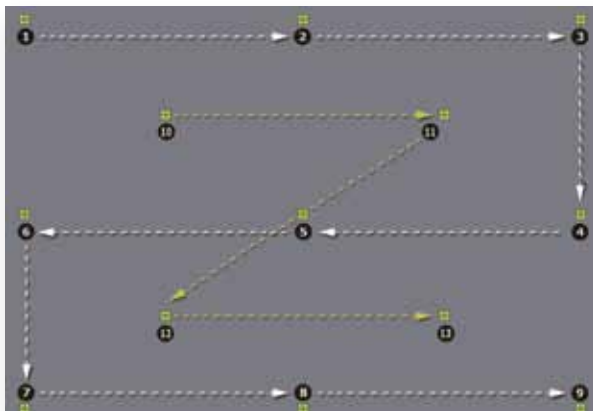



# Using Mouse mode (default)

---

The light pen can be used instead of the computer mouse.

Directly press the light pen against the screen as if you were pressing the left mouse key, double pressing the screen for the double mouse click, or choose the right mouse key button on the LightPen Tool Bar to right click on the screen. When using the mouse function on the toolbar, the pointer will automatically change to the right mouse key if the pointer stays in the same position for 2-3 seconds.







# Accessories

---

Pointer

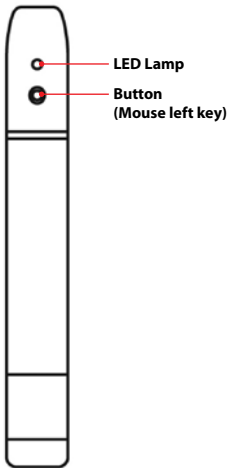

While pressing the button an infra red signal is emitted from the tip of the rod and the CMOS sensor in the projector detects the position of it. While the IR is emitted, the LED Lamp also lights red.

1. Position the tip of the pointer on the screen.
2. Push the button to click the target as a mouse or push and hold the button to draw a line as a pen.

Light pen

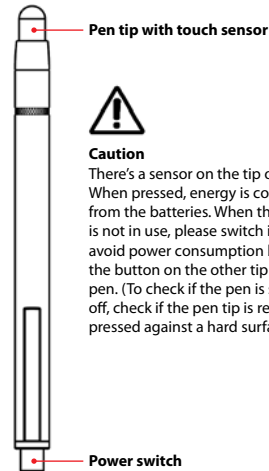

**Caution**

There's a sensor on the tip of the pen. When pressed, energy is consumed from the batteries. When the pen is not in use, please switch it off to avoid power consumption by clicking the button on the other tip of the pen. (To check if the pen is switched off, check if the pen tip is red when pressed against a hard surface.)

When the pen tip is pressed on a hard surface, an infra red signal is emitted to the projector which uses a CMOS detector to detect the position of the pen. When infrared signals are emitted, the pen tip will emit red light.

1. Position the pen tip anywhere on the screen
2. Press the tip of the pen on the hard screen. To draw lines, choose the pen tool.

# Icon functions

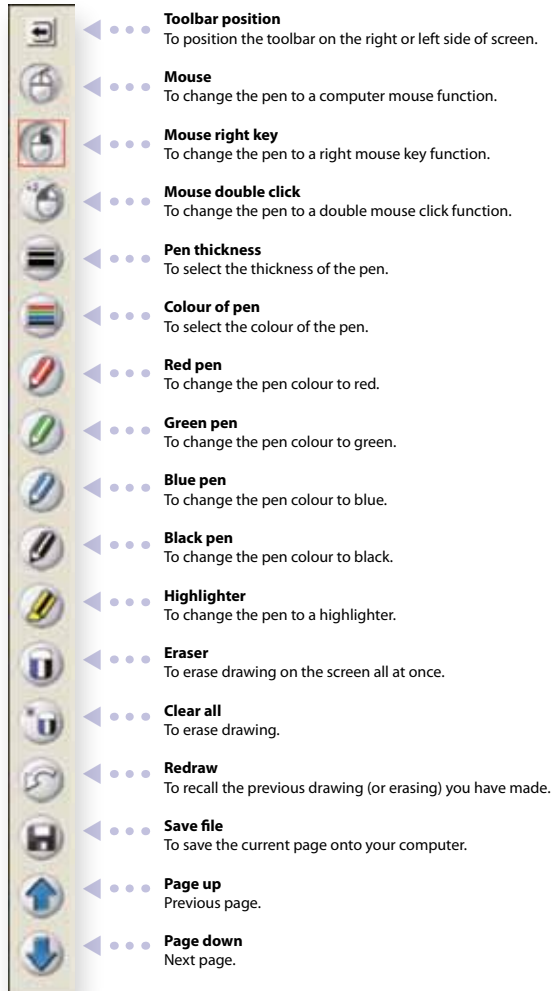
- 
- Toolbar position**  
To position the toolbar on the right or left side of screen.
  - Mouse**  
To change the pen to a computer mouse function.
  - Mouse right key**  
To change the pen to a right mouse key function.
  - Mouse double click**  
To change the pen to a double mouse click function.
  - Pen thickness**  
To select the thickness of the pen.
  - Colour of pen**  
To select the colour of the pen.
  - Red pen**  
To change the pen colour to red.
  - Green pen**  
To change the pen colour to green.
  - Blue pen**  
To change the pen colour to blue.
  - Black pen**  
To change the pen colour to black.
  - Highlighter**  
To change the pen to a highlighter.
  - Eraser**  
To erase drawing on the screen all at once.
  - Clear all**  
To erase drawing.
  - Redraw**  
To recall the previous drawing (or erasing) you have made.
  - Save file**  
To save the current page onto your computer.
  - Page up**  
Previous page.
  - Page down**  
Next page.



# Support

---

## **Free technical helpline**

---

**Tel:** 0870 386 1900 Option 4

---

**Email:** [technical@geneeworld.com](mailto:technical@geneeworld.com)

---

**Website:** [www.geneeworld.com](http://www.geneeworld.com)

---

3 year warranty

---





*Leaders in learning technology*

---

**Genee World**  
**PO Box 3256**  
**Wolverhampton**  
**WV3 0LA**

---

**Sales Tel:** 0870 386 1900  
**Fax:** 0870 405 0188  
**Email:** [enquiries@geneeworld.com](mailto:enquiries@geneeworld.com)  
**Web:** [www.geneeworld.com](http://www.geneeworld.com)

---